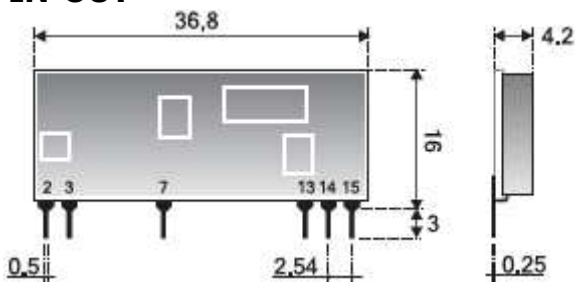

DESCRIPTION

RX-8ML5++F is an AM OOK super-heterodyne receiver working in 868,3MHz ISM band. It has an high sensitivity (-109 dBm) and high rejection to the image frequency obtained by the input conversion in double balanced configuration. The input narrowband saw filter joined with a particular output digital filter allow to have an high immunity to radiated electromagnetic noises as brush motors or other similar actuators. An output RSSI is available and it shows a distance indication from the matched transmitter, as an analogic signal proportional to the effective RF input power.

PIN-OUT

2
15

CONNECTIONS

| | | |
|---------------|------------------------------|--|
| Pin 2 | Ground | GND |
| Pin 3 | Antenna | Antenna connection, 50 ohm impedance. |
| Pin 7 | Ground | GND |
| Pin 13 | RSSI OUT – Test Point | Analogic output RSSI, proportional to the effective RF input power (see details on page 3) |
| Pin 14 | Uscita dati | Data output. Normally low in absence of the input RF signal. |
| Pin 15 | +V | +5V voltage supply. |

Technical features are subjected to change without notice. AUR°EL S.p.A doesn't assume any responsibility for damages due improper use.

Technical features

| | Min | Typical | Max | Unit | Notes |
|---|----------------------|---------|---------|-------------|------------|
| Reception frequency | 868,25 | 868,3 | 868,35 | MHz | |
| V_s voltage supply | 4,7 | 5 | 5,5 | V | |
| Current supply | | 10 | | mA | |
| RF sensitivity | -107 | -109 | -112 | dBm | See note 1 |
| Modulation | | ASK | | | |
| RF bandwidth -3dB | | 600 | | KHz | |
| IF bandwidth -3dB | | 360 | | KHz | |
| Interference rejection to ±10MHz | 70 | 75 | | dB | |
| Interference rejection to ±2MHz | 60 | 65 | | dB | |
| Output square wave | | 2 | 3 | KHz | |
| Output impedance (pin 14) | | 5 | | Kohm | |
| Logic output low level (pin 14) | | | gnd+0,4 | V | See note 3 |
| Logic output high level (pin 14) | V _s x 0,8 | | | V | See note 3 |
| Spurious RF emission in antenna | | | -60 | dBm | |
| Switching on time | | | 100 | ms | See note 2 |
| Operating temperature range | -20 | | +80 | °C | |
| Dimensions | 36,8 x 16 x 4.2 mm | | | | |

NOTE 1: Sensitivity obtained by RF generator 99% modulated, system showed in picture 1.

NOTE 2: For switching on time it means the time requested the receiver to reach the technical feature above, from the moment which the power supply is applied.

NOTE 3: Values obtained with 100KΩ of maximum load.

All technical features stated are obtained using the test system below:

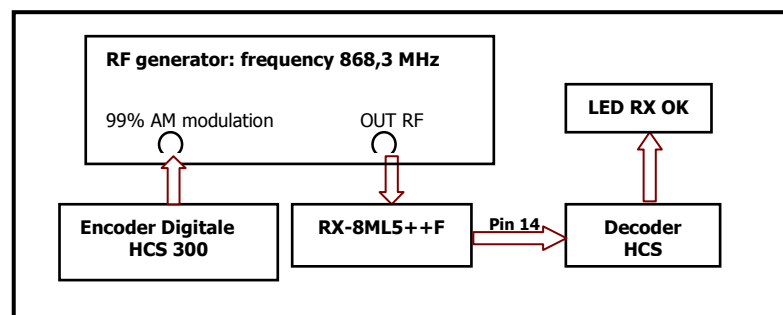

Fig1. Measurement schema of sensitivity.

Technical features are subjected to change without notice. AUR°EL S.p.A doesn't assume any responsibility for damages due improper use.

Pin 13 RSSI output

In picture 1 is shown the values of the RSSI output voltage depending on the RF input power signal. The behavior is obtained applying to the (pin3) antenna of the receiver, from RF generator, an AM modulated signal with 99% modulation index and 1KHz modulating signal. RSSI output has a quite linear behavior (25mV per dB) up to -40 dBm of RF input power, compared at 2V on pin3, point of saturation of the RSSI circuit. In the linear working region RSSI output is proportional to the RF power of the input signal: in this case is possible to use the pin 13 voltage output as measure of the intensity of the input signal power and so knowledge of the distance of the transmitter. When the RSSI pin assumes a constant value, there is no more proportionality with the received signal level.

In this case the value of the Pin 13 output voltage can still be used as an indication of proximity. By calculating the value of RF power above which the RSSI output saturates, we get the maximum distance of the transmitter.

The distance below which the receiver operates in the saturation zone is about 4m (transmitting and receiving antennas in line of sight and under the hypothesis of 0 dBm of transmitted power, typical output power of a handheld transmitter) and depends strongly on the presence of obstacles between the transmitter and receiver (in fact they can cause reflections and multipath matters).

Andamento dell'uscita RSSI in funzione della potenza RF di ingresso

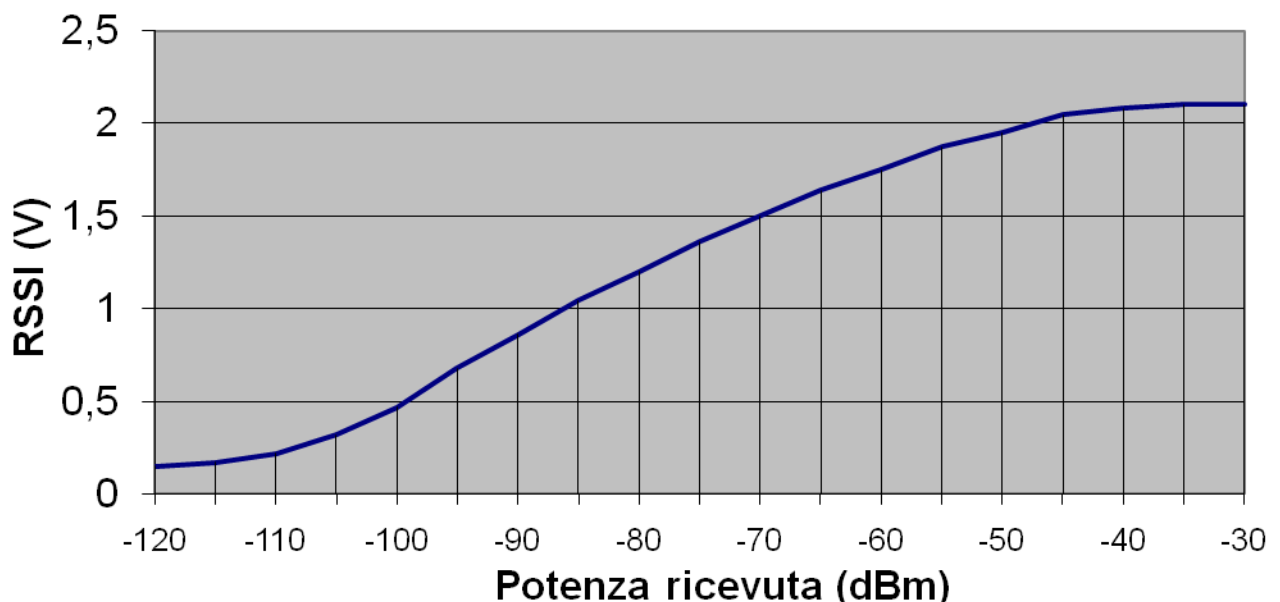

Fig. 1 - RSSI Output diagram

Technical features are subjected to change without notice. AUREL S.p.A doesn't assume any responsibility for damages due improper use.

Device usage

In order to take advantage of the performances described in the technical features and to comply with the operating conditions which characterize the certification, the receiver has to be fitted up on a printed circuit, considering what follows:

Voltage supply:

1. The receiver must be supplied by very low voltage security source protected against short circuits.
2. Maximum voltage variation admitted: ± 0.3 V.
3. De-coupling, next to the receiver, by means of a ceramic capacitor of minimum 100.000 pF value.

Ground:

It must surround in the better way the welding area of the receiver. The circuit must be achieved in double layer, with throughout vias to the ground planes, approximately each 15 mm. It must be properly dimensioned in the antenna connection area, in case a radiant whip antenna is fitted in (and area of approximately 50 mm is suggested).

Fig.2 Lay-out advised for a correct working of the receiver

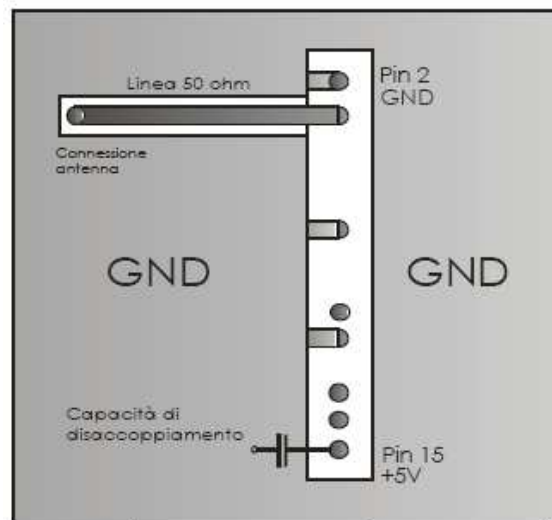

50 Ohm Line:

1. It must be as shorter as possible.
2. 1,8 mm wide for 1 mm thick FR4 printed circuits and 2,9 mm wide for 1,6 mm thick FR4 printed circuits. On the same side it must be kept 2mm away from the ground.
3. On the opposite side a ground circuit area must be present.

Technical features are subjected to change without notice. AUR^oEL S.p.A doesn't assume any responsibility for damages due improper use.

Antenna connections:

It may be utilized as the direct connection point for the radiating whip antenna. It is deeply suggested to put a 100nH inductance from pin 3 to ground in order to protect the device from the electrostatic discharges. It can bear the connection of the central wire of a 50 ohm coaxial cable. Be sure that the braid is welded to the ground in a close point.

1. A whip antenna, 80 mm long and approximately 1 mm dia, brass or copper wire made, must be connected to the RF input of the receiver.
2. The antenna body must be kept straight as much as possible and must be free from other circuits or metal parts (5cm minimum suggested distance).
3. It can be utilized both vertically or horizontally (the previous is highly suggested), providing that connection point between antenna and receiver input is surrounded by a good ground plane.

N.B: As an alternative to the above mentioned antenna it is possible to use the whip model manufactured by Aurel (see related Datasheet and Application Notes).
By fitting whips too different from the described ones, the EEC Certification is not assured.

Other components:

1. Keep the receiver separate from all other components of the circuit (more than 5mm).
2. Keep particularly far away and shielded all microprocessors and their clock circuits.
3. Do not fit components around the 50 Ohm line. At least keep them at 5 mm distance.
4. If the antenna connection is directly used for a radiating whip connection, keep at least a 5 cm radius free area. In case of coaxial cable connection, 5 mm radius will suffice.

REFERENCE NORMATIVE

The RX 4MM5++/F is approved by CE and in particular satisfies the European normative EN 300 220-1 V2.3.1 in class 2, EN 301 489-1 V1.4.1 in class 1. The product was tested in according with EN 60950 normative and it's usable fitted in an isolated housing to ensure the above normative. The receiver must be supplied by very low voltage security source against the short circuits. Usage of receiver module is foreseen fitted in the housing which ensure the agreement of EN 61000-4-2 normative not directly applicable to the module itself. In particular, it's at the user's care the isolating of the extern antenna connection and antenna too, in fact the RF output of the receiver is not able to directly bear electrostatic charges foreseen in the above normative.

Technical features are subjected to change without notice. AUR°EL S.p.A doesn't assume any responsibility for damages due improper use.