

IP68 RATING POLYCARBONATE AND ABS ENCLOSURES



PRODUCT INFORMATION

- The lid and base incorporate a tongue and groove sealing system with continuous silicone seal.
- Wall mounting holes and lid fixing screws are outside the sealing area thus preventing the ingress of moisture and dust.
- Design to IP68 of IEC 529 (Dust and Hose proof).
- Bosses on internal base allow fixing of PCB's horizontally or connection of terminals with M3X4mm self-tapping screws.
- Internal guide slots for mounting PCB assemblies vertically.
- Available with clear or light grey lids.

PC

(P2XX-IP68)
(P2XXC-IP68)

- Material : Polycarbonate (UL94-HB)
- Moulded in : Light grey
- Operating temperature : -40°C to 120°C
- Clear lid is available on request

ABS

(A3XX-IP68)

- Material : High Impact ABS (UL94-HB)
- Moulded in : Dark grey
- Operating temperature : -20°C to 80°C



P203-IP68



P203C-IP68

MATERIAL : POLYCARBONATE		
Light Grey Lid + Light Grey Base	EXTERNAL DIMENSION (mm)	Clear Lid + Light Grey Base
ITEM NO.		ITEM NO.
P201-IP68	64 x 58 x 35	P201C-IP68
P203-IP68	115 x 65 x 40	P203C-IP68
P205-IP68	115 x 65 x 55	P205C-IP68
P212-IP68	115 x 90 x 55	P212C-IP68
P214-IP68	171 x 121 x 55	P214C-IP68
P218-IP68	222 x 146 x 55	P218C-IP68
P221-IP68	115 x 90 x 80	P221C-IP68
P223-IP68	171 x 121 x 80	P223C-IP68
P229-IP68	195 x 80 x 55	P229C-IP68
P232-IP68	222 x 146 x 75	P232C-IP68
P250-IP68	52 x 50 x 35	P250C-IP68
P256-IP68	82 x 80 x 55	P256C-IP68
P258-IP68	160 x 80 x 55	P258C-IP68
P265-IP68	160 x 80 x 85	P265C-IP68
P278-IP68	120 x 120 x 60	P278C-IP68
P279-IP68	120 x 120 x 90	P279C-IP68
P287-IP68	160 x 160 x 60	P287C-IP68
P288-IP68	160 x 160 x 90	P288C-IP68
P2691-IP68	200 x 120 x 75	P2691C-IP68
P2385-IP68	265 x 185 x 95	P2385C-IP68
P2018-IP68	240 x 160 x 90	P2018C-IP68
P2025-IP68	240 x 160 x 120	P2025C-IP68
P20295-IP68	300 x 230 x 86	P20295C-IP68
P20385-IP68	300 x 230 x 111	P20385C-IP68
P20583-IP68	360 x 200 x 150	P20583C-IP68

▲ Lid fixing screws are M4 stainless steel (non-magnetic) into threaded brass inserts.



A304-IP68

MATERIAL : ABS	
Dark Grey Lid + Dark Grey Base	EXTERNAL DIMENSION (mm)
ITEM NO.	
A302-IP68	64 x 58 x 35
A304-IP68	115 x 65 x 40
A308-IP68	115 x 65 x 55
A311-IP68	115 x 90 x 55
A313-IP68	171 x 121 x 55
A317-IP68	222 x 146 x 55
A331-IP68	115 x 90 x 80
A340-IP68	171 x 121 x 80
A346-IP68	195 x 80 x 55
A353-IP68	222 x 146 x 75
A362-IP68	52 x 50 x 35
A366-IP68	82 x 80 x 55
A368-IP68	160 x 80 x 55
A369-IP68	160 x 80 x 85
A386-IP68	120 x 120 x 60
A387-IP68	120 x 120 x 90
A396-IP68	160 x 160 x 60
A399-IP68	160 x 160 x 90
A3735-IP68	200 x 120 x 75
A3783-IP68	265 x 185 x 95
A3008-IP68	240 x 160 x 90
A3019-IP68	240 x 160 x 120
A30285-IP68	300 x 230 x 86
A30312-IP68	300 x 230 x 111
A30393-IP68	360 x 200 x 150

▲ Lid fixing screws are M4 stainless steel (non-magnetic) into threaded brass inserts.

P201-IP68 / P201C-IP68 / A302-IP68

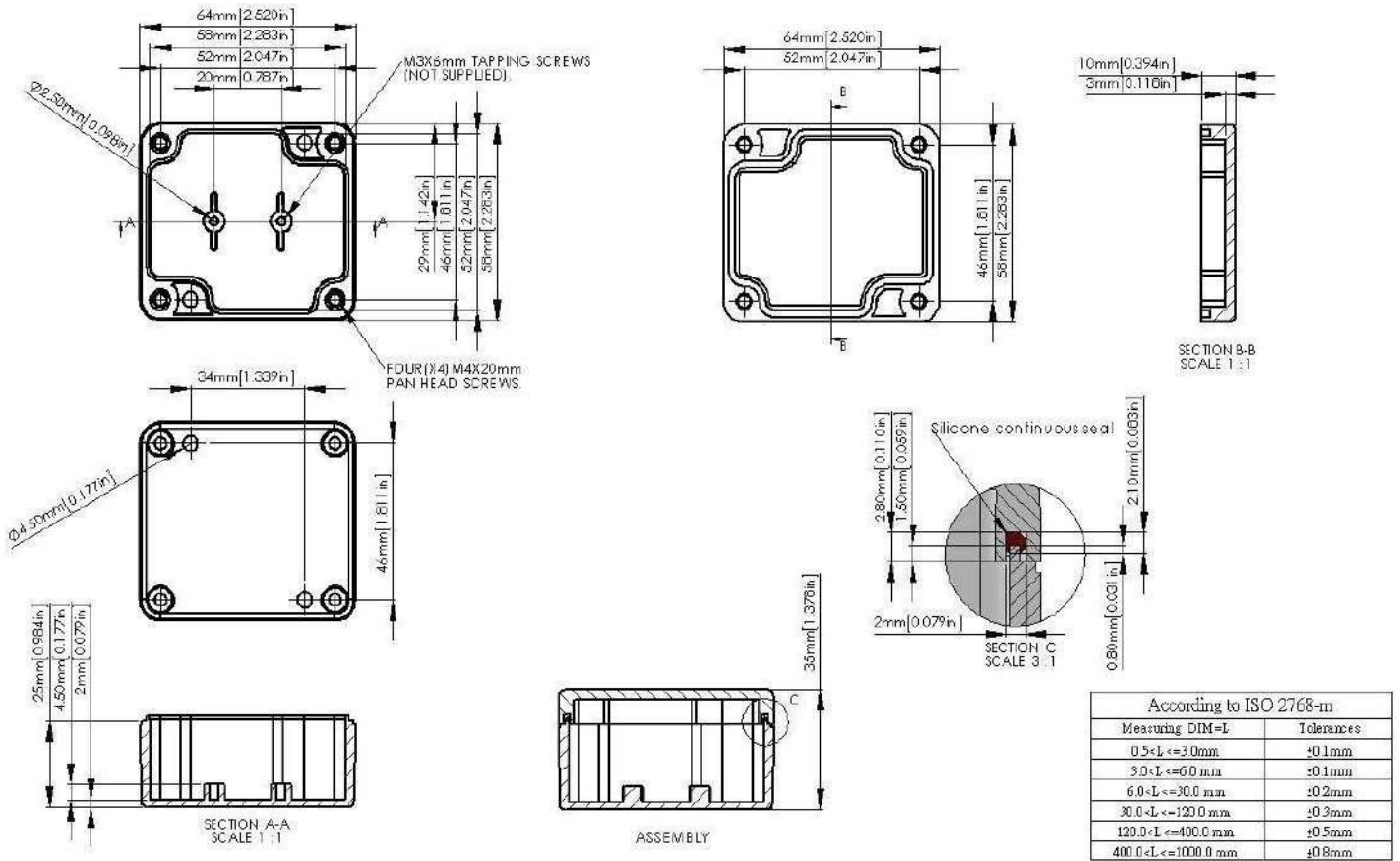

P203-IP68 / P203C-IP68 / A304-IP68

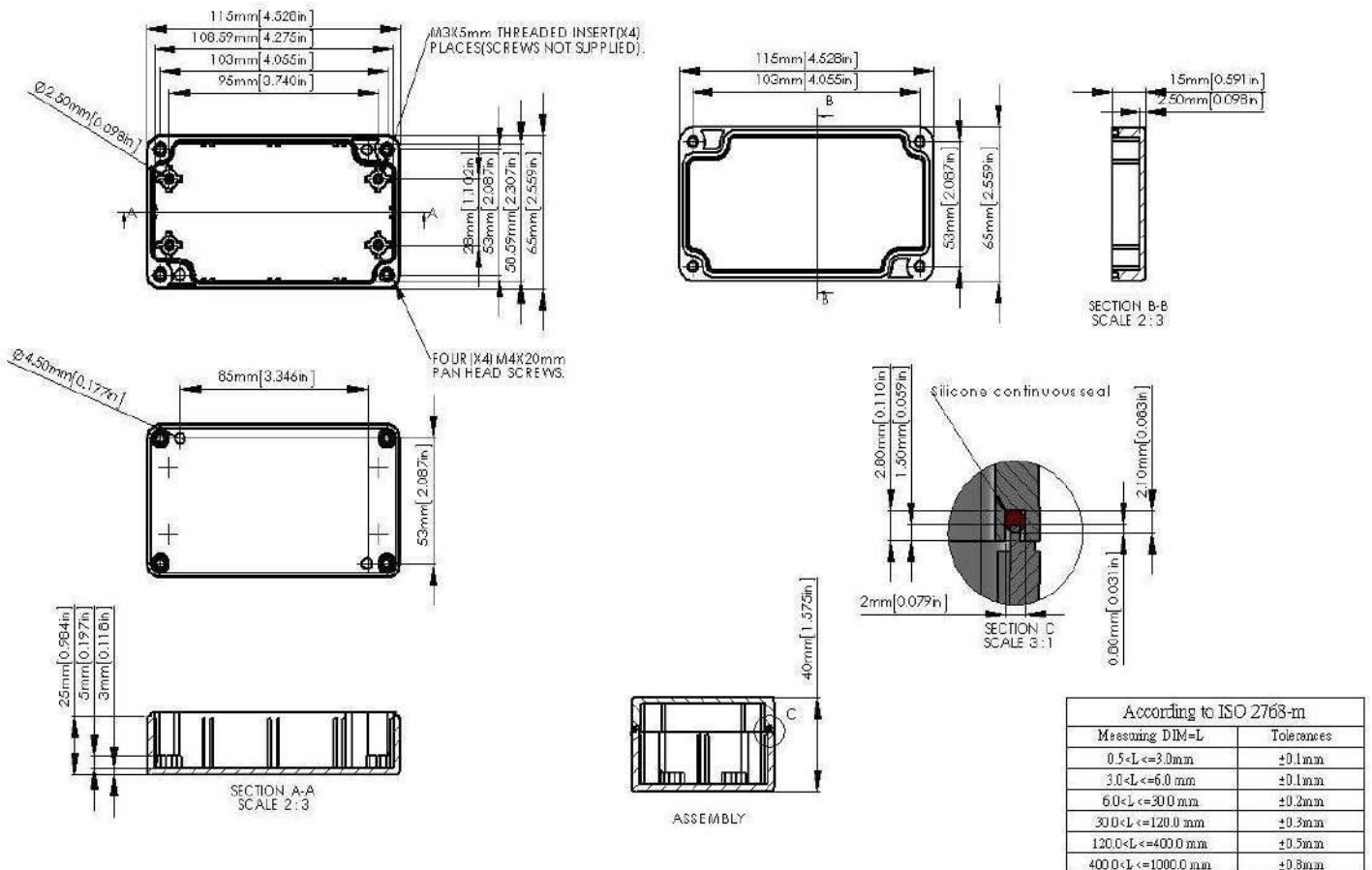

P205-IP68 / P205C-IP68 / A308-IP68

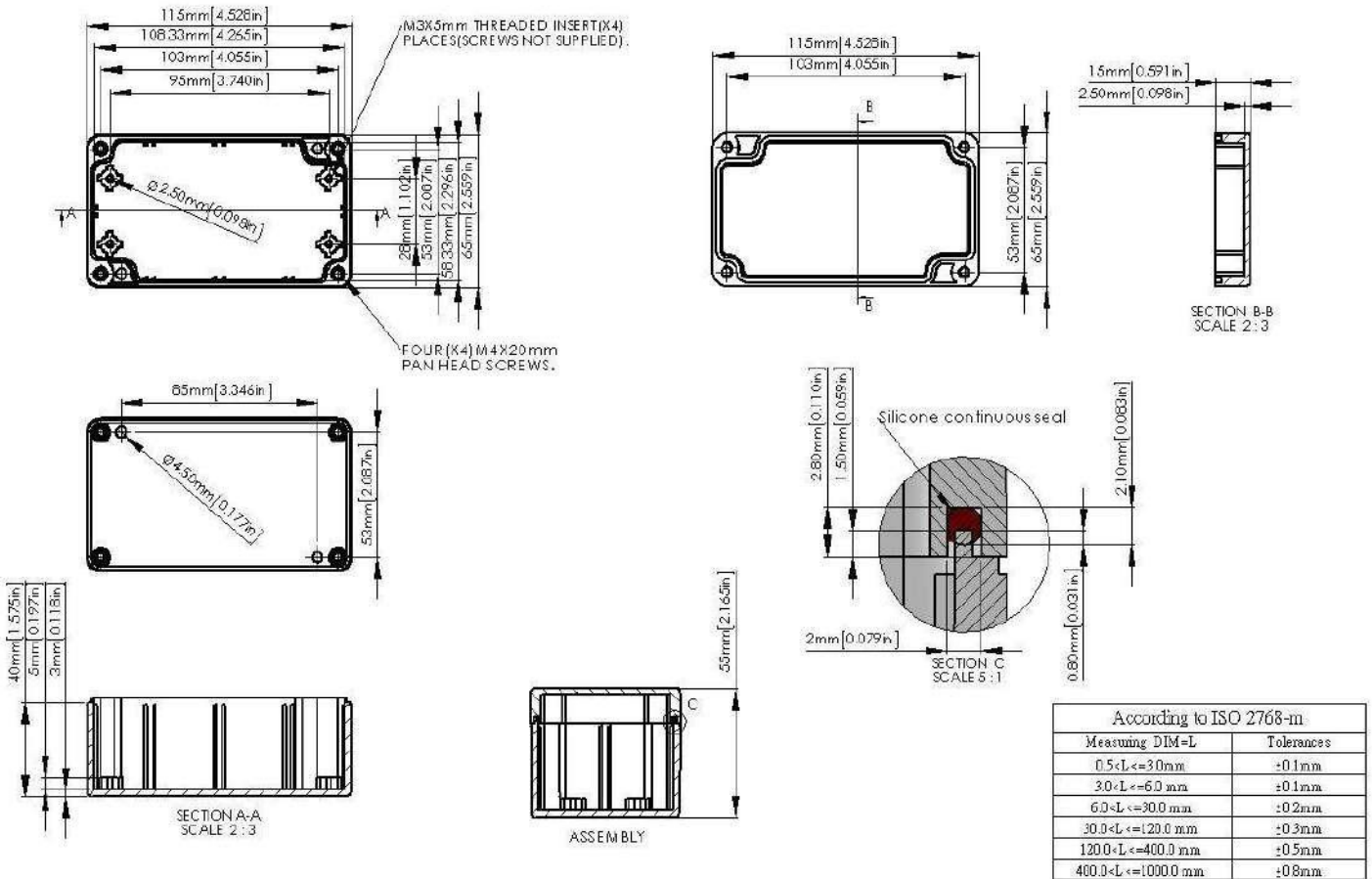

P212-IP68 / P212C-IP68 / A311-IP68

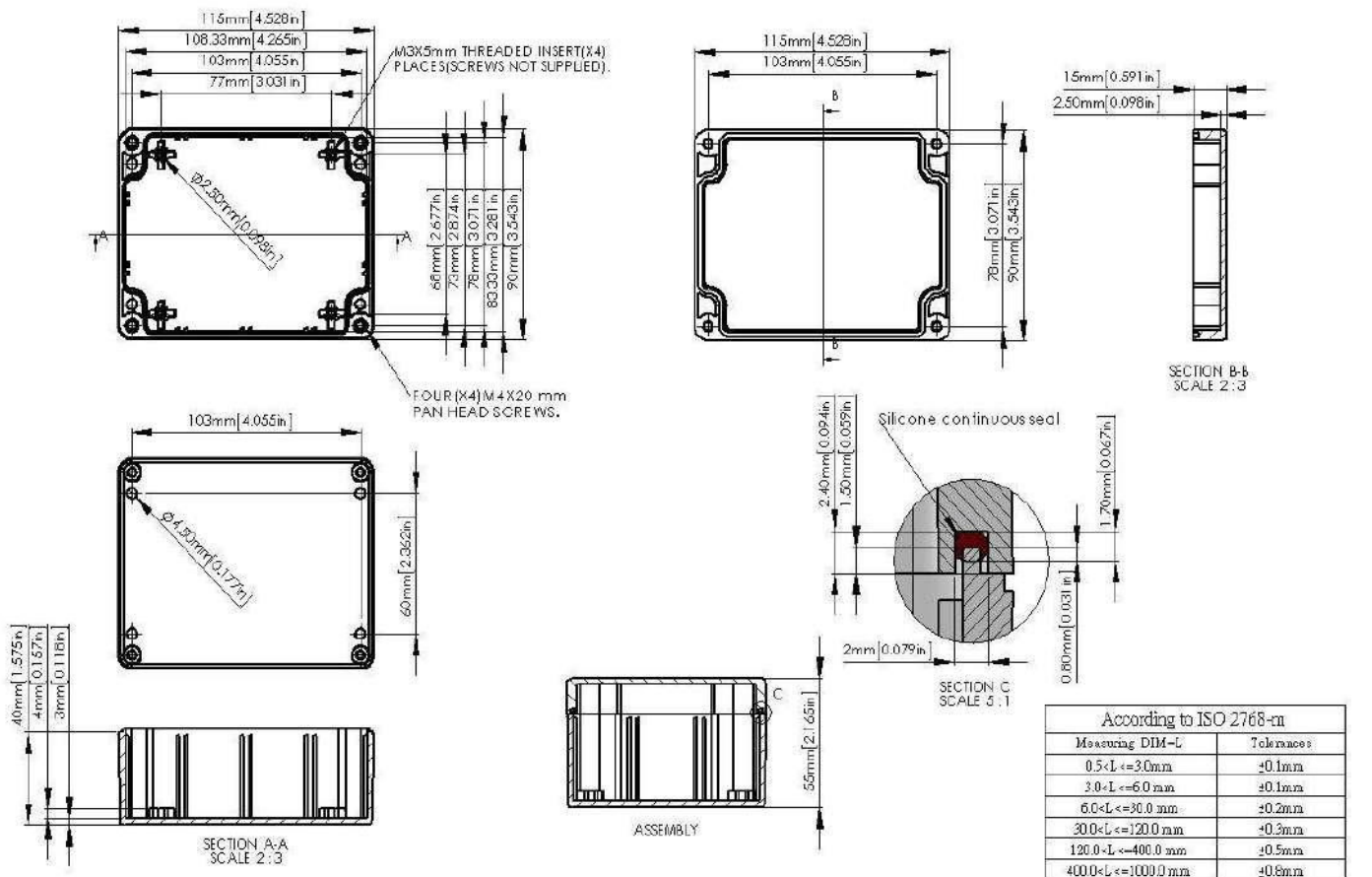

P221-IP68 / P221C-IP68 / A331-IP68

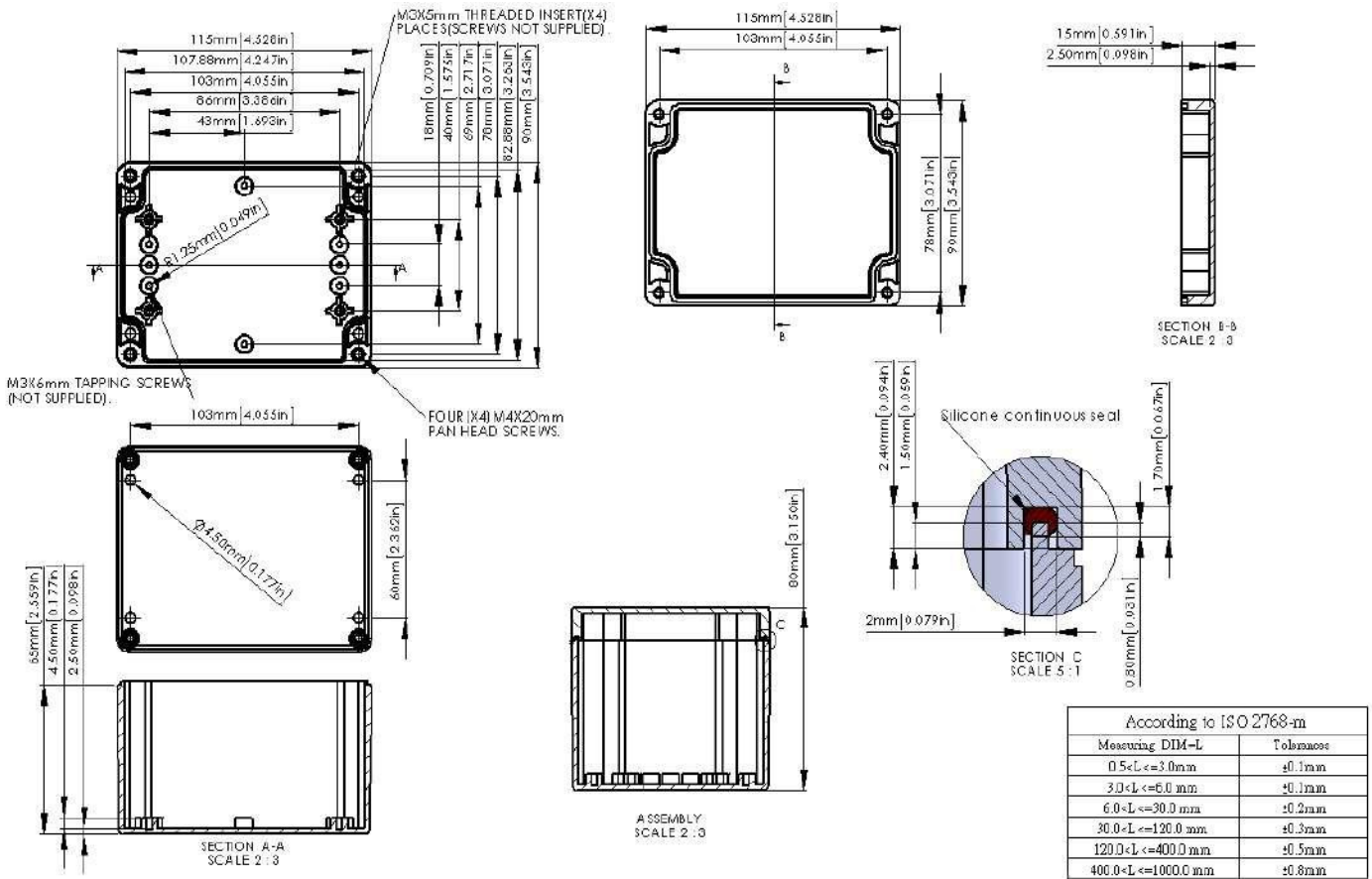

P223-IP68 / P223C-IP68 / A340-IP68

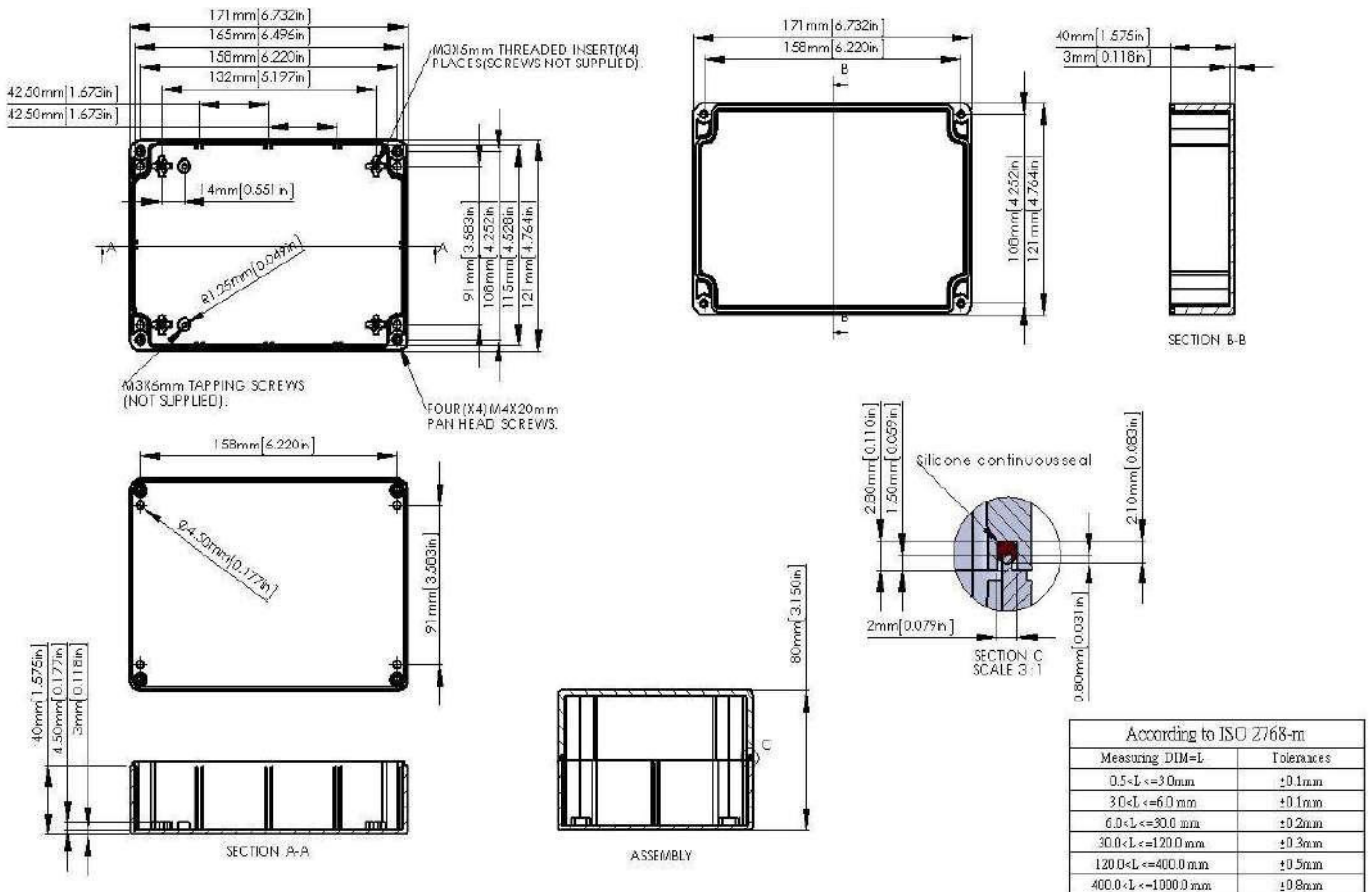

P229-IP68 / P229C-IP68 / A346-IP68

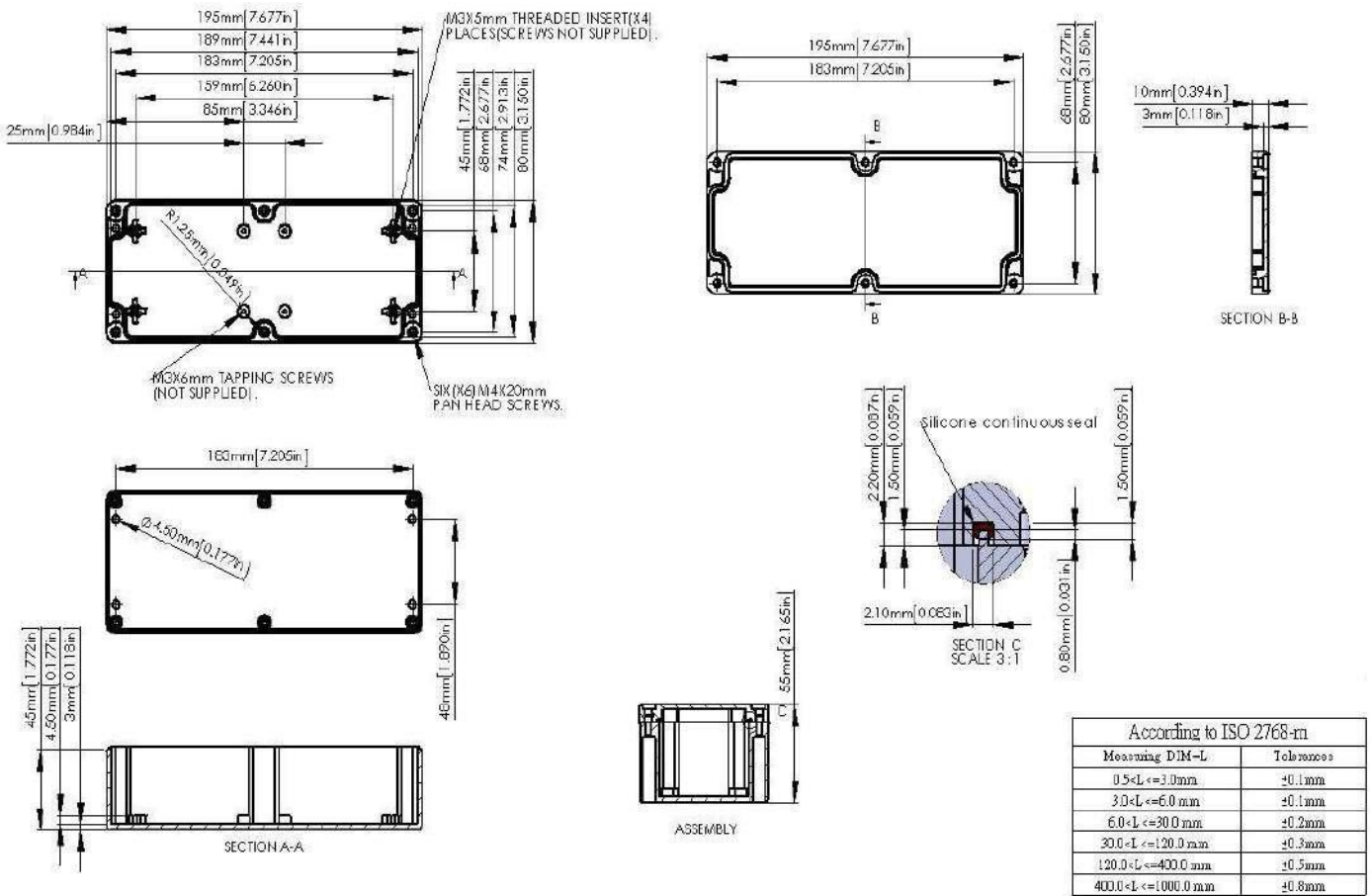

P232-IP68 / P232C-IP68 / A353-IP68

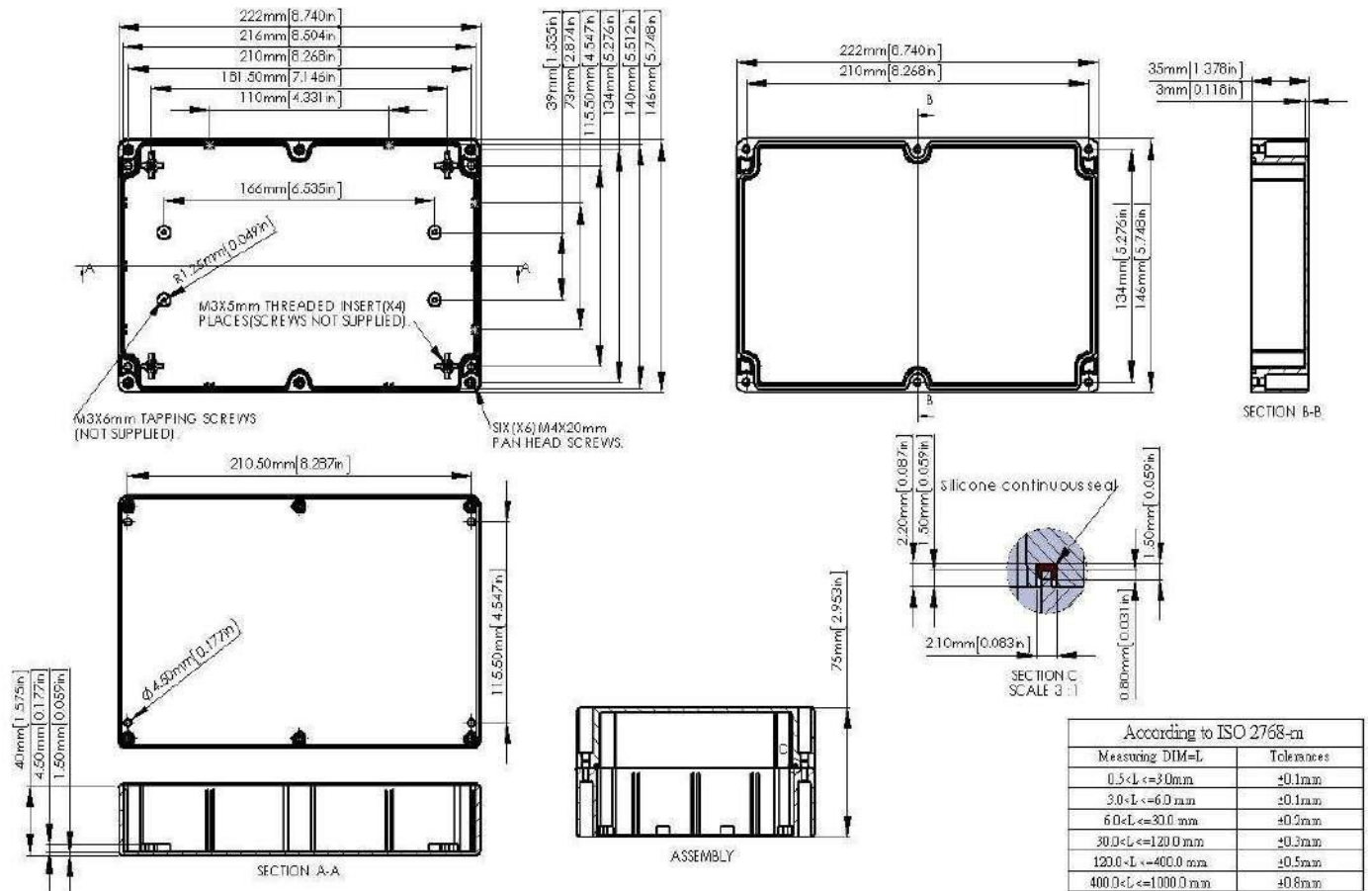

P250-IP68 / P250C-IP68 / A362-IP68

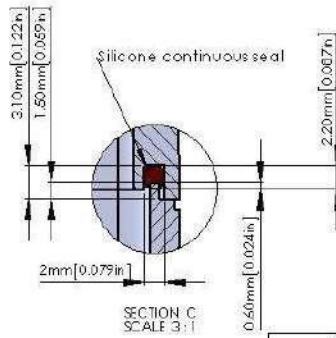
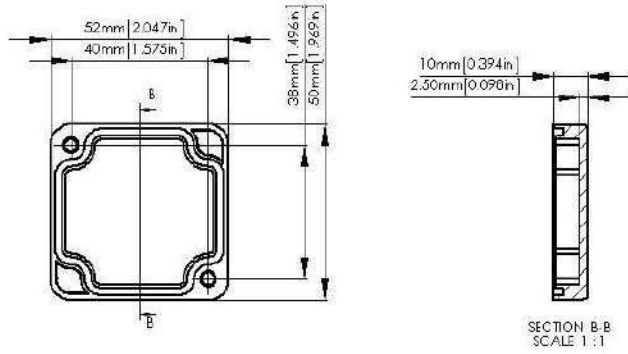
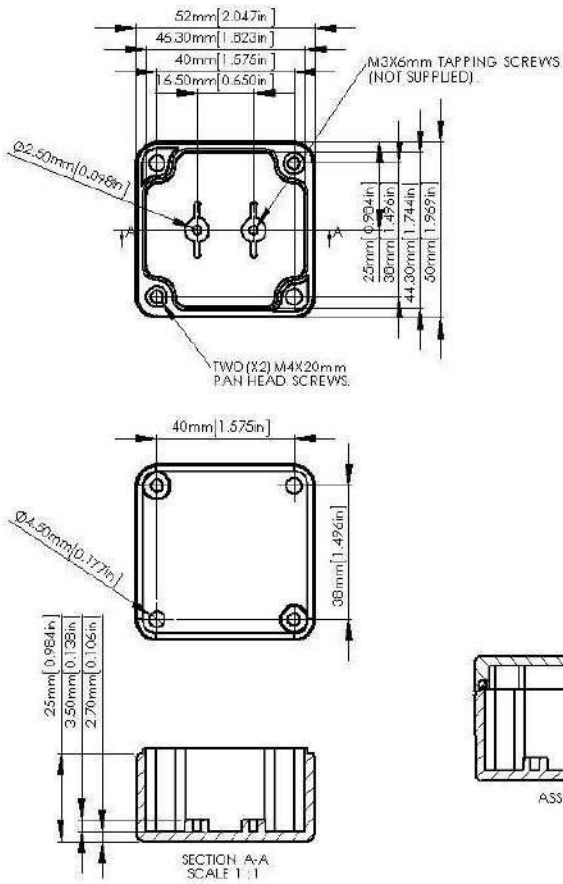

According to ISO 2768-m

Measuring DIM=L	Tolerances
0.5 <L <= 3.0 mm	±0.1 mm
3.0 <L <= 6.0 mm	±0.1 mm
6.0 <L <= 30.0 mm	±0.2 mm
30.0 <L <= 120.0 mm	±0.3 mm
120.0 <L <= 400.0 mm	±0.5 mm
400.0 <L <= 1000.0 mm	±0.8 mm

P256-IP68 / P256C-IP68 / A366-IP68

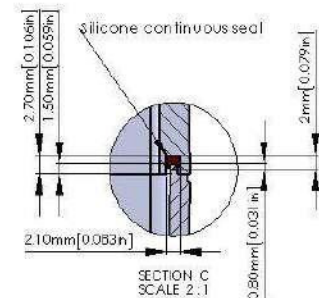
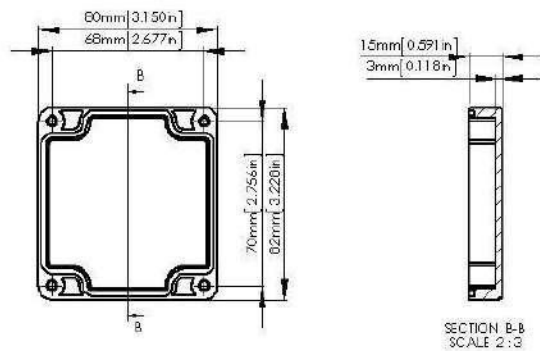
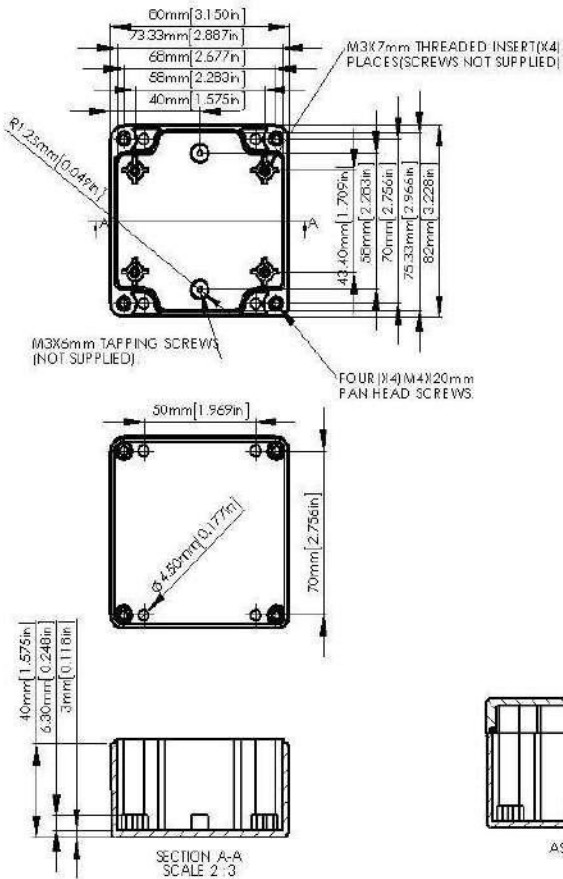

According to ISO 2768-m

Measuring DIM=L	Tolerances
0.5 <L <= 3.0 mm	±0.1 mm
3.0 <L <= 6.0 mm	±0.1 mm
6.0 <L <= 30.0 mm	±0.2 mm
30.0 <L <= 120.0 mm	±0.3 mm
120.0 <L <= 400.0 mm	±0.5 mm
400.0 <L <= 1000.0 mm	±0.8 mm

P258-IP68 / P258C-IP68 / A368-IP68

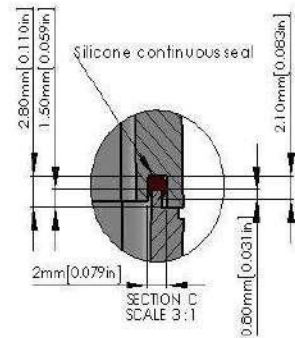
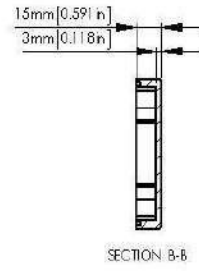
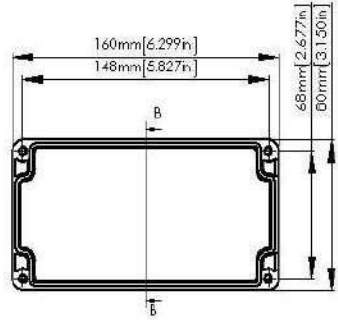
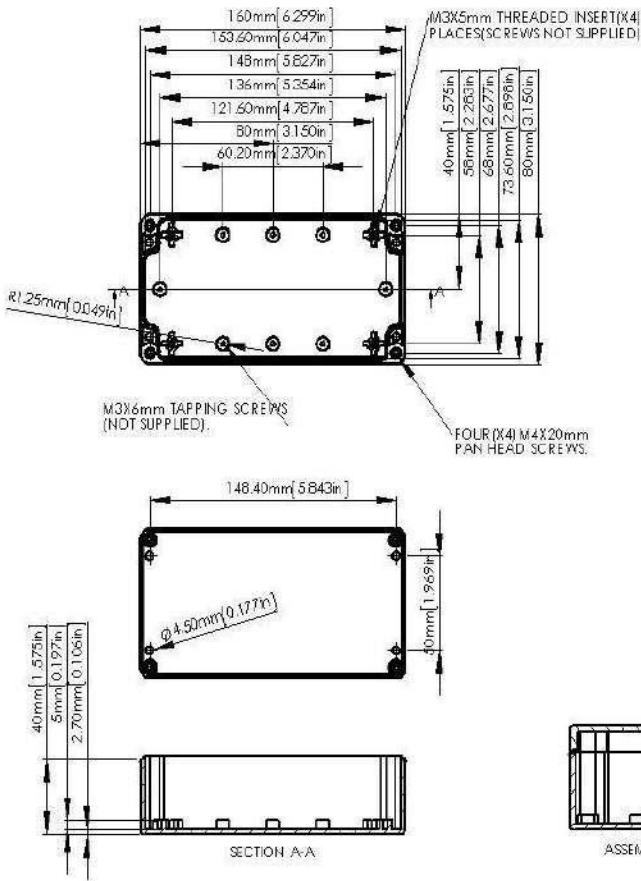

According to ISO 2768-m

Measuring DIM-L	Tolerances
0.5 < L ≤ 3.0 mm	±0.1 mm
3.0 < L ≤ 6.0 mm	±0.1 mm
6.0 < L ≤ 30.0 mm	±0.2 mm
30.0 < L ≤ 120.0 mm	±0.3 mm
120.0 < L ≤ 400.0 mm	±0.5 mm
400.0 < L ≤ 1000.0 mm	±0.8 mm

P265-IP68 / P265C-IP68 / A369-IP68

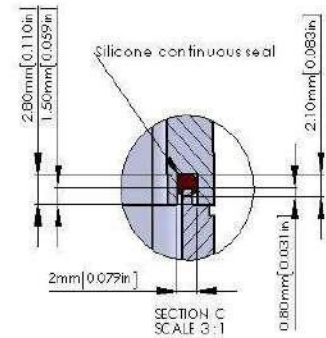
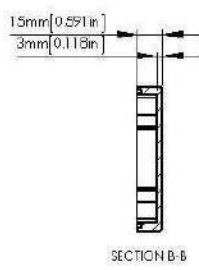
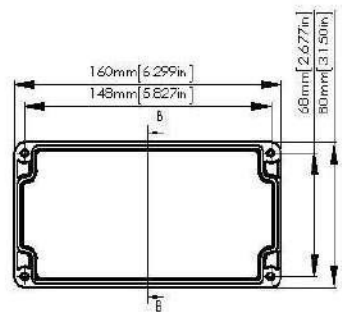
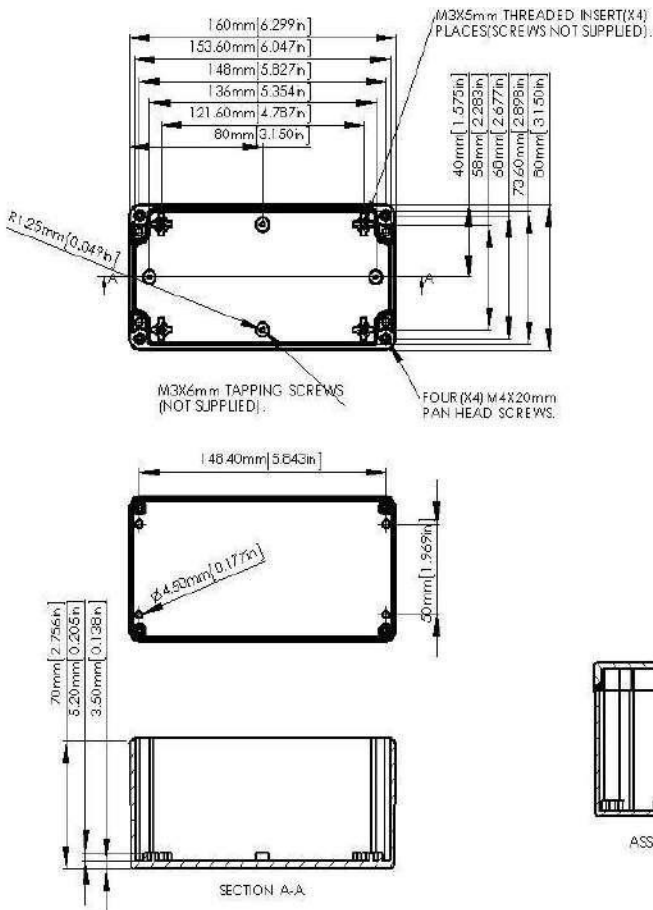

According to ISO 2768-m

Measuring DIM-L	Tolerances
0.5 < L ≤ 3.0 mm	±0.1 mm
3.0 < L ≤ 6.0 mm	±0.1 mm
6.0 < L ≤ 30.0 mm	±0.2 mm
30.0 < L ≤ 120.0 mm	±0.3 mm
120.0 < L ≤ 400.0 mm	±0.5 mm
400.0 < L ≤ 1000.0 mm	±0.8 mm

P278-IP68 / P278C-IP68 / A386-IP68

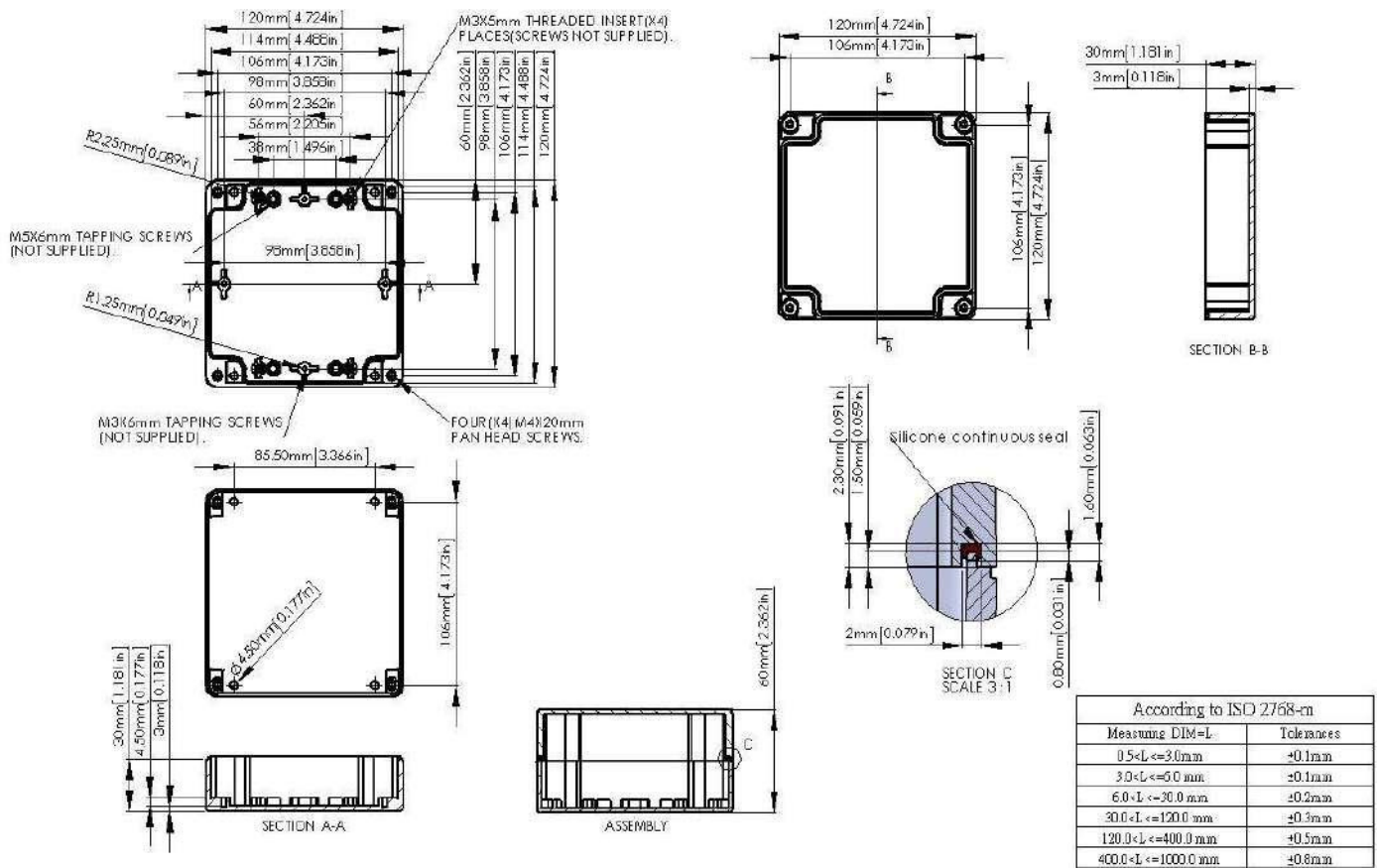

P279-IP68 / P279C-IP68 / A387-IP68

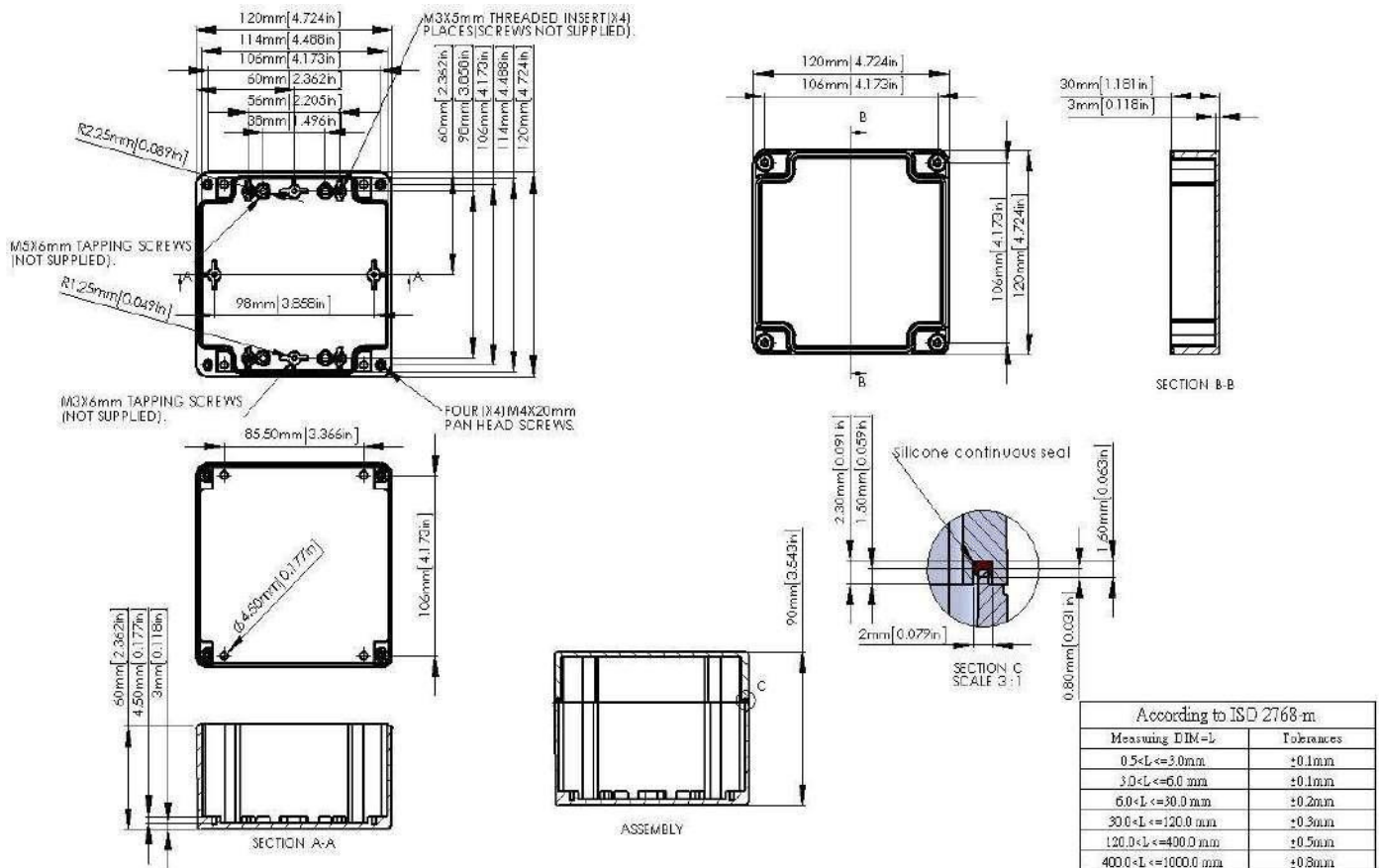

P287-IP68 / P287C-IP68 / A396-IP68

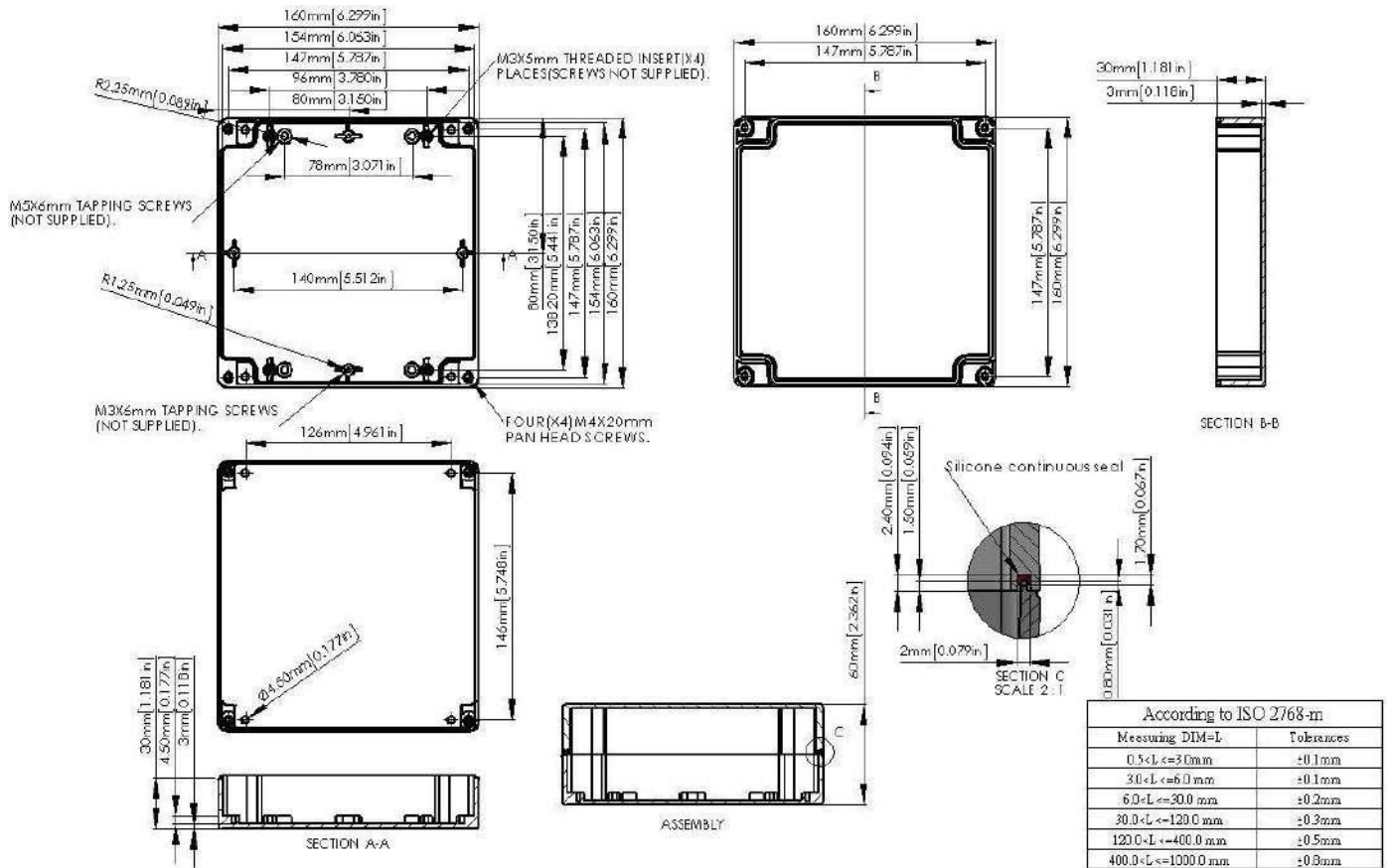

P288-IP68 / P288C-IP68 / A399-IP68

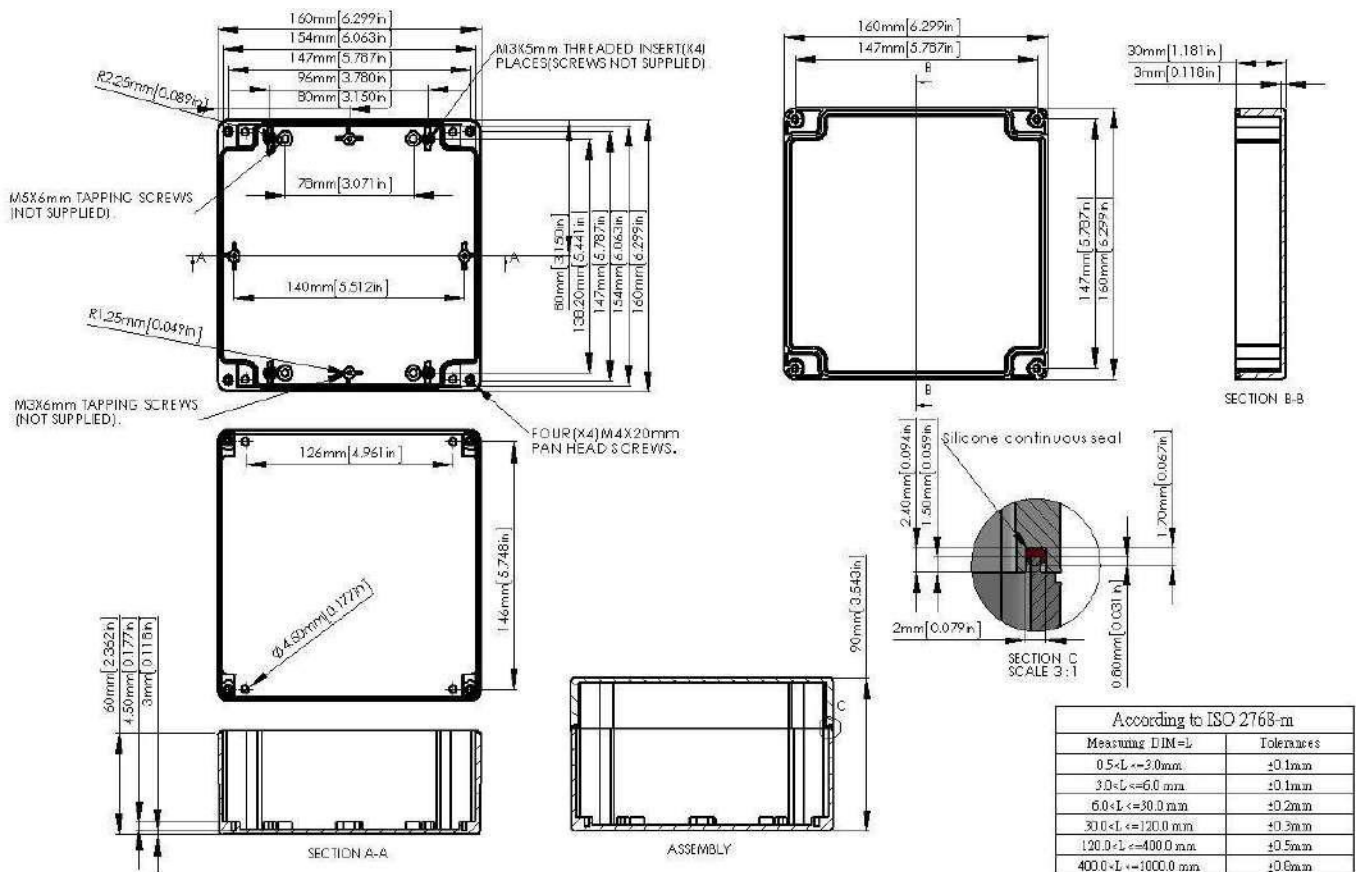

P2691-IP68 / P2691C-IP68 / A3735-IP68

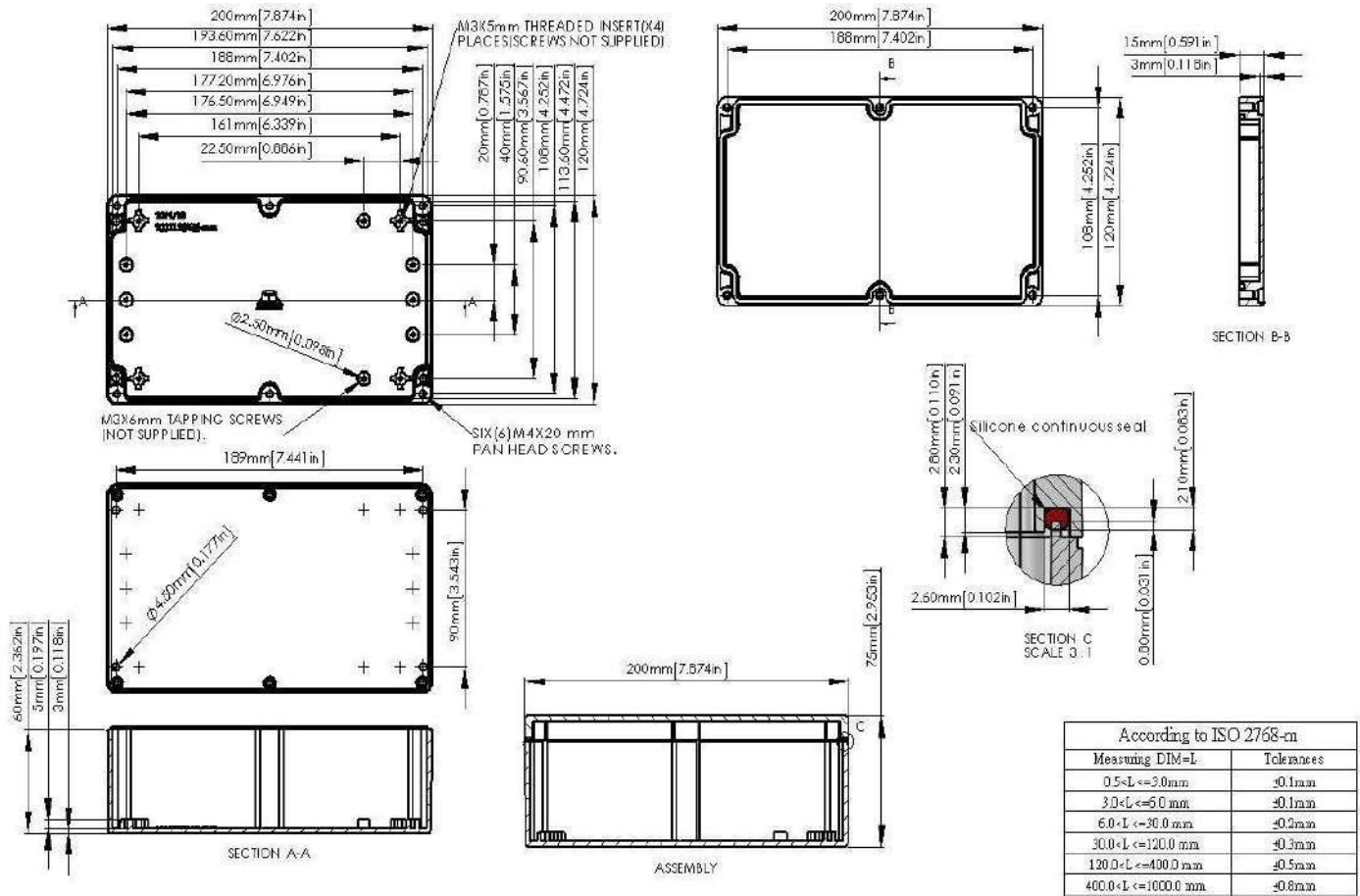

P2385-IP68 / P2385C-IP68 / A3783-IP68

